

FIG. 1<sup>c</sup>  
(DOORSNEDE A-B)

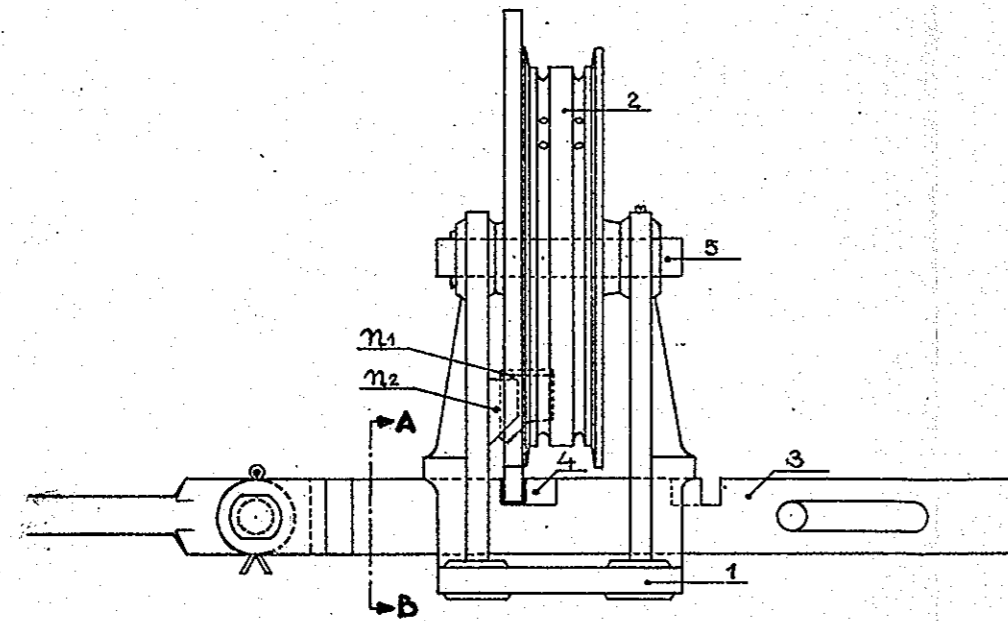

FIG. 1<sup>a</sup>

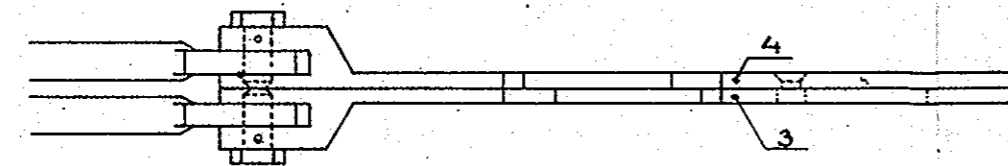

FIG. 1<sup>b</sup>

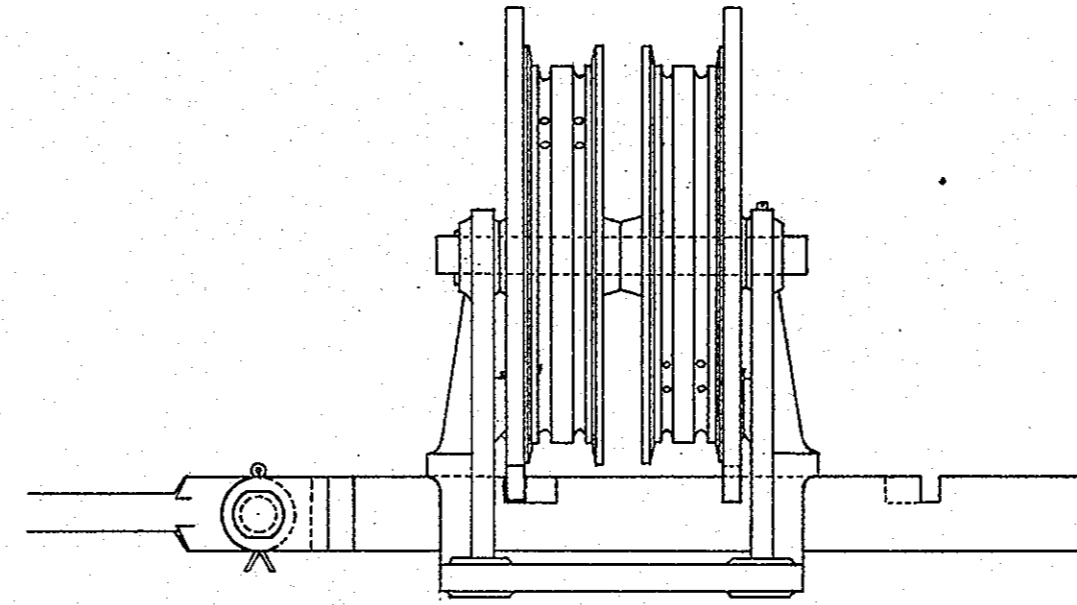

FIG. 2<sup>a</sup>

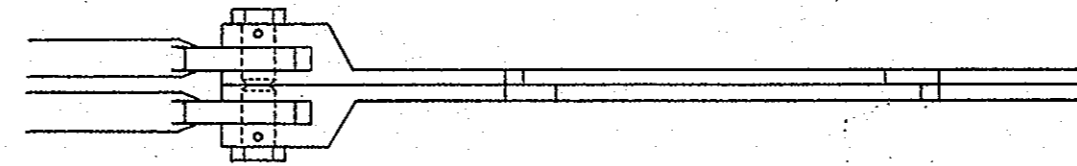

FIG. 2<sup>b</sup>

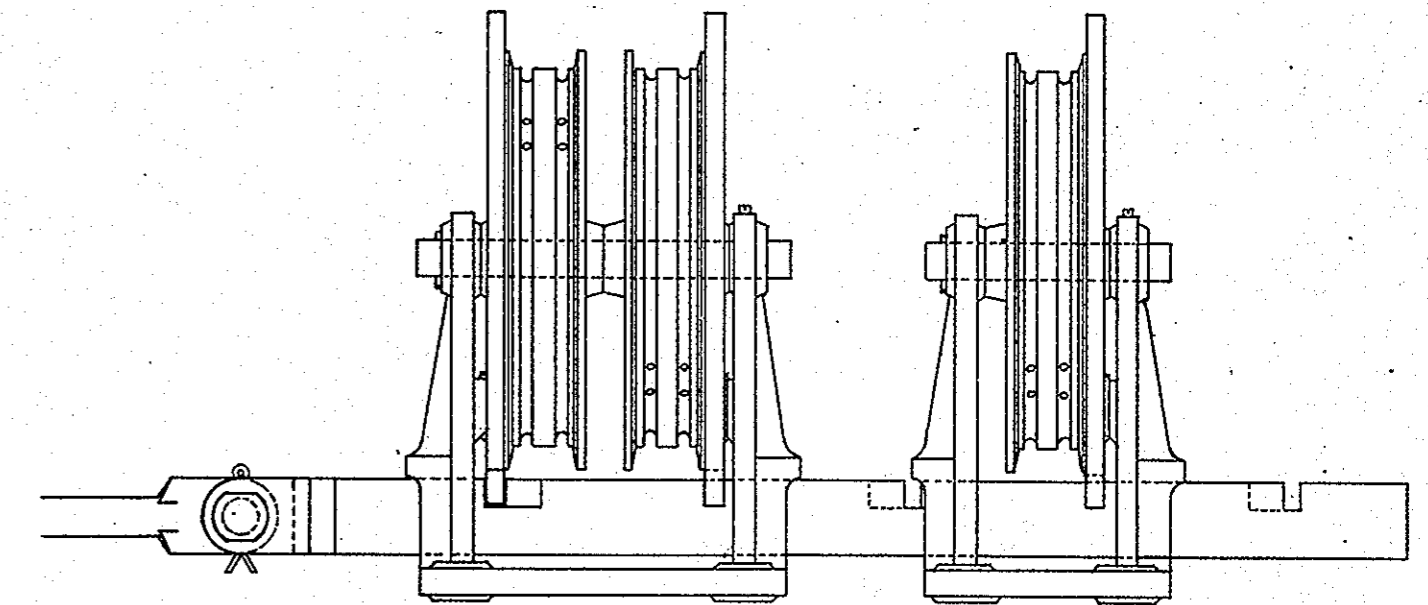

FIG. 3<sup>a</sup>

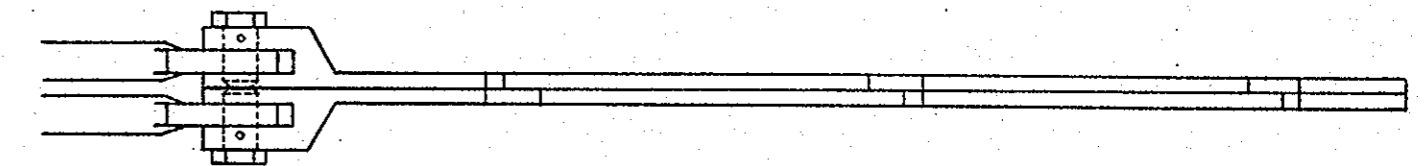

FIG. 3<sup>b</sup>

WUZE VAN AANKOPPELING DER DRADEN

BU RECHTSE STUITING

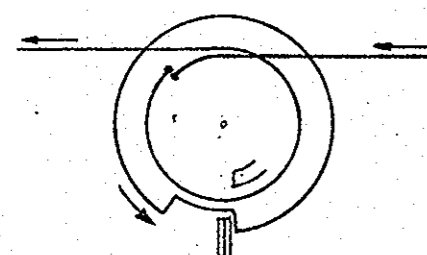

FIG. 4

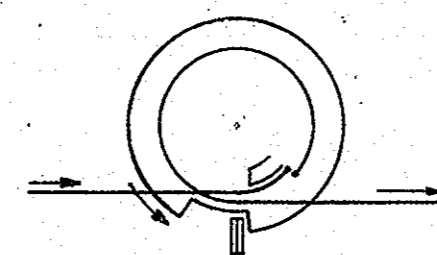

FIG. 5

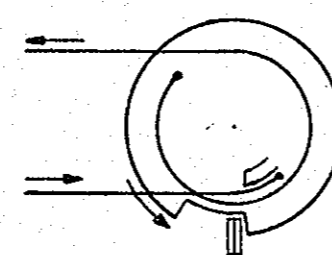

FIG. 6

BU LINKSE STUITING

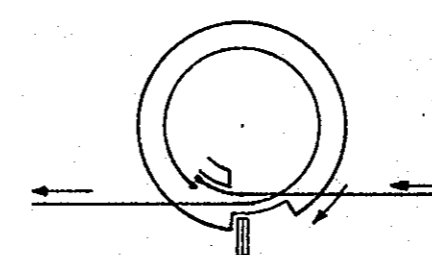

FIG. 7

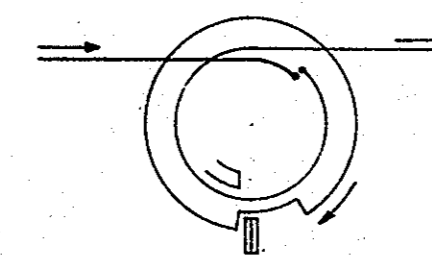

FIG. 8

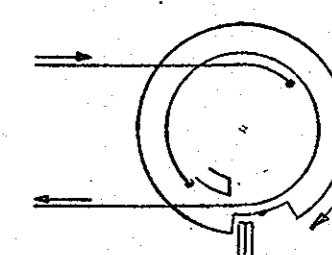

FIG. 9